

# Mathematical Model of Stabilization of an Electrohydraulic System

Gulsara Annakulova<sup>1, a)</sup> and Sarvar Saidov<sup>b)</sup>

<sup>1</sup>*Institute of Mechanics and Seismic Stability of Structures named after M.T.Urazbaev, Uzbekistan Academy of Sciences, 100125, Tashkent, Dormon yuli, 40, Uzbekistan.*

<sup>a)</sup> Corresponding author: annaqulova\_g@mail.ru

<sup>b)</sup> sarvar\_said@mail.ru

**Abstract.** A mathematical model for stabilizing the hydraulic motor of an electro-hydraulic control system is proposed. A Lyapunov function ensuring system stability is defined. To determine the optimal stabilizing function of the hydraulic system, the Bellman equation is derived using the method of dynamic programming. The optimal stabilizing function for electro-hydraulic servo drives has been established. Based on the proposed stabilization model of the electro-hydraulic servo system, implemented in the Matlab-Simulink environment, variations of system pressure and the angular displacement of the hydraulic motor shaft were obtained, both with and without the stabilizing function, which adequately describes the operating process of the hydraulic system.

## INTRODUCTION

An important direction in automatic control theory is the stabilization of systems. The problem of analyzing and synthesizing the stability of motion in various physical systems, particularly hydraulic control systems, remains one of the most pressing issues in mechanics and control theory. Advanced hydraulic systems of transport vehicles are characterized by the expansion of the functional capabilities of control systems, for which it is necessary to develop new schematic solutions for electro-hydraulic control systems with qualitatively new parameters and characteristics.

The information process from the processing of primary data to the impact of control signals on actuators, together with the devices implementing this process, is called a motion control system. The entire set consisting of the moving object, its motion control system, and terminal elements (measuring devices and actuators) is referred to as a controlled dynamic system [1]. Among the problems of optimal control, an important place is occupied by stabilization of a given motion. In [2], the problem of stabilizing dynamic systems in the case of asymptotic stability of a specified motion is formulated. These are problems of constructing control actions that ensure stable desired motion with the best possible quality of the transient process [3, 4].

The stabilization problem is related to the general problem of motion stability. Methods for studying problems of optimal stabilization are connected with the classical methods of Lyapunov stability theory [5,6]. In the problem of stabilization of both dynamic and hydraulic systems, two tasks arise: a) it is required to find a stabilizing control  $u(x,t) \in U$ ; b) the control is given in advance  $u(x,t)$ , and it is necessary to verify whether the equilibrium state of the system is asymptotically stable  $x = 0$  or not [7]. Studies [8, 9] are devoted to methods of nonlocal synthesis of stabilization systems for programmed motions. For many dynamic systems, two problem formulations of synthesis are used. In the first formulation, the control is sought as a function of time and the initial state of the system, i.e., in the form of optimal programmed control. In the second formulation, the synthesis problem assumes finding the optimal control as a function of the current state of the controlled system and time, i.e., in the form of feedback control. The solution to the control synthesis problem in the first formulation employs Pontryagin's maximum principle [10], whereas solving the same problem in the second formulation reduces to solving Bellman's functional equations [11]. In [12], the basic principles and techniques of mathematical modeling of hydraulic control systems are presented, along with certain stabilization methods used in hydro-automation. In [13], the fundamentals of the theory and

methods for calculating the dynamic characteristics of hydraulic transmission elements (pumps, hydraulic motors, spool valves, hydraulic boosters) are described. Hydraulic systems with mechanical feedback and with electromechanical control are also presented. In [14], nonlinear mathematical models of servo hydraulic drives of various classes are introduced. The influence of nonlinearities on drive dynamics is considered, as well as special types of motion under the combined action of several nonlinearities. In [15], an experimental setup representing a prototype of a standard hydraulic forestry crane is studied. A regulator design with a time-varying gain coefficient is proposed. Lyapunov-based analysis is presented to demonstrate the stability and convergence properties of the algorithms. For analyzing the asymptotic stability of the origin, a continuous positive definite Lyapunov function is found such that for any solution of the problem under consideration, monotonic decrease is ensured. In [16], a mathematical model of a servo-hydraulic motor was developed, taking into account the compressibility of the working fluid, leakages, and friction. The model parameters were determined based on experimental data and comparison with simulation results. A PID controller implemented in the Simulink environment was used to control the motor speed. The controller design was based on the response of the linear model to a step input. The overshoot that arises when applying the controller to the nonlinear system was eliminated by tuning the PID controller coefficients. In [17], a mathematical model of a variable-rate fertilizer application system was developed, consisting of an electromagnetic proportional valve and a hydraulic motor controlled through the valve. To regulate the motor's rotational speed, a PID controller was applied, with its parameters tuned using the Ziegler–Nichols method. In the MATLAB-Simulink environment, transient process analyses were carried out for P, PI, and PID algorithms. The results showed that the system with a PID controller exhibited the best dynamic and static characteristics: high response speed, low steady-state error, and good tracking capability.

## PHYSICAL FORMULATION OF THE PROBLEM

Let us consider the functional diagram of the electro-hydraulic servo system (EHSS) shown in Fig. 1. The system operates as follows. The working fluid from the pump is supplied to the electro-hydraulic distributor (EHD), which is controlled by an electrical signal from the controller and redirects the flow toward the hydraulic motor. Under the action of the fluid flow, the hydraulic motor begins to rotate, resulting in the formation of an angular velocity  $\dot{\alpha}$ . The rotation parameters are measured by sensors, and the obtained data are transmitted to the controller through the signal transmission system. The controller analyzes the incoming information and generates a control action on the EHD, ensuring stable and precise operation of the system.

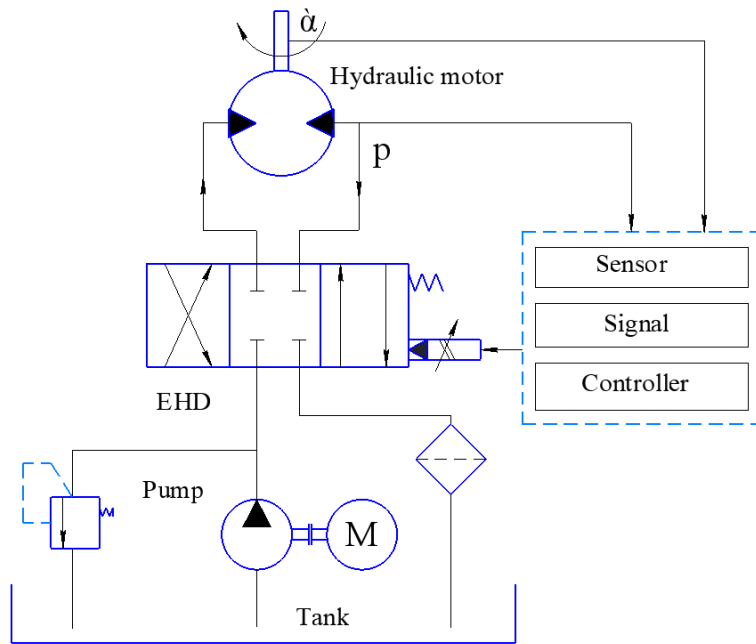

FIGURE 1. Functional diagram of the electro-hydraulic drive system

## MATHEMATICAL FORMULATION OF THE PROBLEM

The flow rate of the working fluid passing through the spool valve of the electro-hydraulic control (EHC) system is expressed as [4]:

$$Q_L = k_q x \sqrt{\frac{p_s - p_d - p_l \text{sign} x}{2}}, \quad (1)$$

$$\text{sign}(x) = \begin{cases} 1, & x > 0, \\ 0, & x = 0, \\ -1, & x < 0. \end{cases}$$

where  $k_q = \mu_q \pi d_s k_n \sqrt{\frac{2}{\rho}}$  – specific conductance of the spool valve orifices;  $\mu_q$  – flow coefficient of the spool valve orifices;  $d_s$  – spool diameter;  $k_n$  – coefficient of effective utilization of the spool perimeter;  $p_s$  – supply pressure of the electro-hydraulic distributor (EHD);  $p_d$  – drain pressure of the EHD;  $p_l$  – load pressure (the pressure difference in the chambers of the hydraulic motor).

Linearizing the right-hand side of equation (1) in the vicinity of, with constant values of the drain pressure and the supply pressure of the drive, expression (1) can be replaced by the following equation [4]:

$$Q_L = K_{Qx} x - K_{Qp} p_l, \quad (2)$$

The equation of motion of the output shaft of the hydraulic motor, taking into account the inertial load, has the following form [5]:

$$J_m \frac{d^2 \alpha}{dt^2} + k_{fr} \frac{d\alpha}{dt} = q_m p_l, \quad (3)$$

where  $J_m$  – the moment of inertia reduced to the shaft of the hydraulic motor from the controlled EHSS devices and the rotating parts of the hydraulic motor;  $k_{fr}$  – the coefficient characterizing hydraulic friction in the hydraulic motor.

The flow balance equation, taking into account the compressibility of the fluid in the pipelines connecting the electro-hydraulic control unit (EHC) with the hydraulic motor and in the chambers of the hydraulic motor, is written in the following form [5]:

$$\frac{V_0}{2B} \frac{dp_l}{dt} + k_{pm} p_l = Q_L - q_m \frac{d\alpha}{dt}, \quad (4)$$

where  $V_0$  – the volume of the hydraulic line between the electro-hydraulic distributor (EHD) and the hydraulic motor, including the connected chambers of the hydraulic motor;  $B$  – bulk modulus of elasticity;  $q_m$  – characteristic volume of the hydraulic motor;  $\alpha$  – angular displacement of the hydraulic motor shaft.

The voltage at the output of the angular displacement sensor of the hydraulic motor shaft is compared at the input of the EHC with the control voltage  $u_{in}$

$$u_c = (u_{in} - K_p \alpha),$$

where  $K_p$  – positional feedback coefficient.

Let us consider the system of equations (3)–(4), whose block diagram is shown in Fig. 2.

Let us introduce the notations

$$\alpha = y_1, \quad \dot{\alpha} = y_2, \quad p_H = y_3. \quad (6)$$

Thus, the system of differential equations (3) and (4), taking into account (6), takes the following form:

$$\begin{aligned} \frac{dy_1}{dt} &= y_2, \\ \frac{dy_2}{dt} &= -\frac{k_{fr}}{J_m} y_2 + \frac{q_m}{J_m} y_3, \\ \frac{dy_3}{dt} &= \frac{2Bq_m}{V_0} y_1 + (K_{Qp} - k_{pm}) \frac{2B}{V_0} y_3 + K_{Qx} \frac{2B}{V_0} x. \end{aligned} \quad (7)$$

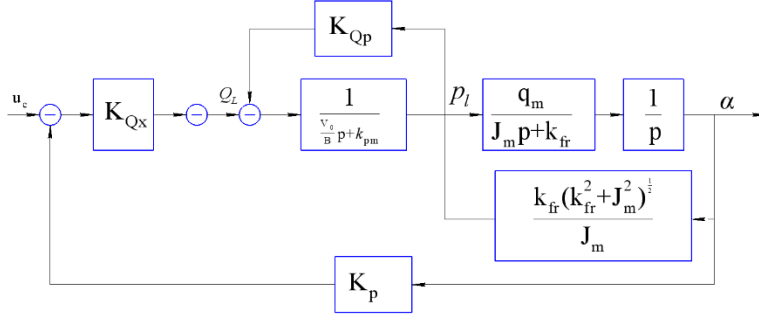

**FIGURE 2.** Block diagram of the linear model of the electro-hydraulic servo system (EHSS)

Let us determine the steady-state solution of system (7). The equations for finding the steady-state solution take the following form:

$$\begin{aligned}
 y_2 &= 0, \\
 -\frac{k_{fr}}{J_m} y_2 + \frac{q_m}{J_m} y_3 &= 0, \\
 -\frac{2Bq_m}{V_0} y_1 + (K_{Qp} - k_{pm}) \frac{2B}{V_0} y_3 + K_{Qx} \frac{2B}{V_0} x &= 0.
 \end{aligned} \tag{8}$$

From this, we find that

$$y_1 = \frac{K_{Qx} x_0}{q_m}, y_2 = 0, y_3 = 0. \tag{9}$$

Thus, the stationary solutions of the system take the following form:

$$y_{10} = \frac{K_{Qx} x_0}{q_m}, y_{20} = 0, y_{30} = 0. \tag{10}$$

The task consists in selecting regulator constants such that the obtained solution would possess Lyapunov stability. From the system of equations (7), by means of transformations according to the formulas

$$y_1 = y_{10} + x_1, y_2 = y_{20} + x_2, y_3 = y_{30} + x_3, \tag{11}$$

we obtain the equations of perturbed motion, which take the form

$$\begin{aligned}
 \dot{x}_1 &= x_2, \\
 \dot{x}_2 &= -\frac{k_{fr}}{J_m} x_2 + \frac{q_m}{J_m} x_3, \\
 \dot{x}_3 &= \frac{2Bq_m}{V_0} x_1 - (K_{Qp} - k_{pm}) \frac{2B}{V_0} x_3.
 \end{aligned} \tag{12}$$

Let us study the stability of the stationary solutions of system (12). The stationary equations are given as:

$$\begin{aligned}
 x_2 &= 0, \\
 -\frac{k_{fr}}{J_m} x_2 + \frac{q_m}{J_m} x_3 &= 0, \\
 -\frac{2Bq_m}{V_0} x_1 - (K_{Qp} - k_{pm}) \frac{2B}{V_0} x_3 &= 0.
 \end{aligned} \tag{13}$$

Relations (11) define the transformation of shifting the origin of coordinates to the point with coordinates  $(y_{10}, y_{20}, y_{30})$ , as a result, solution (13) corresponds to the solution of equations (12).

$$x_k = 0, \quad k = 1, 2, 3. \tag{14}$$

Let us consider the Lyapunov function in the form

$$V = \frac{1}{2}(x_1^2 + x_2^2 + x_3^2) \quad (15)$$

Let us determine the derivative of the function  $V$ . By virtue of the system of equations (12):

$$\frac{dV}{dt} = x_1\dot{x}_1 + x_2\dot{x}_2 + x_3\dot{x}_3. \quad (16)$$

Then, in accordance with (12), we have

$$\frac{dV}{dt} = -\frac{k_{fr}}{J_m}x_2 - \left( \frac{k_{pm} \cdot 2B_{mp}}{V_0} - K_{Qp} \right) x_3^2 - q_m x_1 x_3 + x_1 x_2 + \frac{q_m}{J_m} x_2 x_3. \quad (17)$$

As can be seen from relation (17), the condition

$$\frac{dV}{dt} < 0 \quad (18)$$

is satisfied under the condition

$$\frac{k_{pm} 2B}{V_0} - K_{Qp} > 0. \quad (19)$$

It should be noted that if conditions (18) and (19) are satisfied, the function  $V$  is positive everywhere, while  $\dot{V}$  has the opposite sign and, therefore, according to Lyapunov's theorem, the perturbed motion in the considered case is stable.

Stabilization of system (12). Let us consider the system of equations (12) taking into account an unknown stabilizing function  $u = u(x_1, x_2, x_3)$ :

$$\begin{aligned} \dot{x}_1 &= x_2, \\ \dot{x}_2 &= -\frac{k_{fr}}{J_m}x_2 + \frac{q_m}{J_m}x_3 + u, \\ \dot{x}_3 &= \frac{2Bq_m}{V_0}x_1 - \left( K_{Qp} - k_{pm} \right) \frac{2B}{V_0}x_3. \end{aligned} \quad (20)$$

As the specified point we take  $x_* = \left( \frac{K_{Qx} x_0}{q_m}, 0, 0 \right)$ , from (10), the origin of coordinates; i.e., we set  $x_* = 0$ . The quality of the control process will be evaluated by the performance functional [7].

$$I = \int_0^T (x_1^2 + x_2^2 + x_3^2 + u^2) dt. \quad (21)$$

Let us determine the optimal strategy  $u = u(x_1, x_2, x_3)$ , that effects the transfer of the phase point from an arbitrary initial state to the origin, and does so such that the cost functional (21) attains its minimum value along the resulting trajectories.

The Bellman functional equation is represented in the form:

$$\begin{aligned} \min_u \left[ x_1^2 + x_2^2 + x_3^2 + u^2 + \frac{\partial s}{\partial x_1} x_2 + \frac{\partial s}{\partial x_2} \left( -\frac{k_{fr}}{J_m} x_2 - \frac{q_m}{J_m} x_3 + u \right) + \right. \\ \left. + \frac{\partial s}{\partial x_3} \left( -q_m x_1 + \left( K_{Qp} - \frac{k_{pm} \cdot 2B}{V_0} \right) x_3 \right) \right]. \end{aligned} \quad (22)$$

To determine the minimum in (22), we differentiate the right-hand side of equation (22) with respect to  $u$  and set the result equal to zero.

$$2u + \frac{ds}{dx_2} = 0. \quad (23)$$

From expression (23) we determine

$$u = -\frac{1}{2} \frac{ds}{dx_2} \quad (24)$$

The solution of equation (22) will be sought in the form

$$s(x) = b_1 x_1^2 + b_2 x_2^2 + b_3 x_3^2. \quad (25)$$

The partial derivatives of  $s(x)$  are expressed in the form

$$\frac{\partial s}{\partial x_1} = 2b_1 x_1, \quad \frac{\partial s}{\partial x_2} = 2b_2 x_2, \quad \frac{\partial s}{\partial x_3} = 2b_3 x_3. \quad (26)$$

Substituting relations (26) into (22), we obtain

$$\begin{aligned} & x_1^2 + x_2^2 + x_3^2 - (b_2 x_2)^2 + 2b_1 x_1 x_2 - \frac{2b_2 k_{fr}}{J_m} x_2^2 + 2b_3 q_m x_1 x_3 + \\ & + \frac{2b_2 q_m}{J_m} x_2 x_3 - 2b_2^2 x_2^2 + 2b_3 \left( K_{Qp} - \frac{k_{pm} \cdot 2B}{V_0} \right) x_3^2 = 0. \end{aligned} \quad (27)$$

The values of the coefficients  $b_1$ ,  $b_2$  and  $b_3$  are determined from the system of equations

$$b_1 = 0, \quad b_2^2 + \frac{2k_{fr}}{J_m} b_2 - 1, \quad b_3 = -\frac{V_0}{2(K_{Qp} V_0 - k_{pm} 2B)} \quad (28)$$

$$b_1 = 0, \quad b_2 = -\frac{k_{fr}}{J_m} \pm \frac{\sqrt{k_{fr}^2 + J_m^2}}{J_m}, \quad b_3 = -\frac{V_0}{2(K_{Qp} V_0 - k_{pm} 2B)}. \quad (29)$$

The system of equations (28) has two real solutions

$$b_1 = 0, \quad b_2 = -\frac{k_{fr}}{J_m} + \frac{\sqrt{k_{fr}^2 + J_m^2}}{J_m}, \quad b_3 = -\frac{V_0}{2(K_{Qp} V_0 - k_{pm} 2B)} \quad (30)$$

$$b_1 = 0, \quad b_2 = -\frac{k_{fr}}{J_m} - \frac{\sqrt{k_{fr}^2 + J_m^2}}{J_m}, \quad b_3 = -\frac{V_0}{2(K_{Qp} V_0 - k_{pm} 2B)}. \quad (31)$$

Solutions (30) and (31), in accordance with relation (24), lead to two synthesizing functions

$$u = \frac{1}{2} \left( \frac{k_{fr}}{J_m} - \frac{\sqrt{k_{fr}^2 + J_m^2}}{J_m} \right) x_2, \quad (32)$$

$$u = \frac{1}{2} \left( \frac{k_{fr}}{J_m} + \frac{\sqrt{k_{fr}^2 + J_m^2}}{J_m} \right) x_2. \quad (33)$$

From relations (32) and (33), the stabilization of the system can be ensured by expression (32). Thus, the optimal synthesizing function is given by equation (32).

## RESULTS AND DISCUSSION

Figure 3 shows the block diagram of the optimal system.

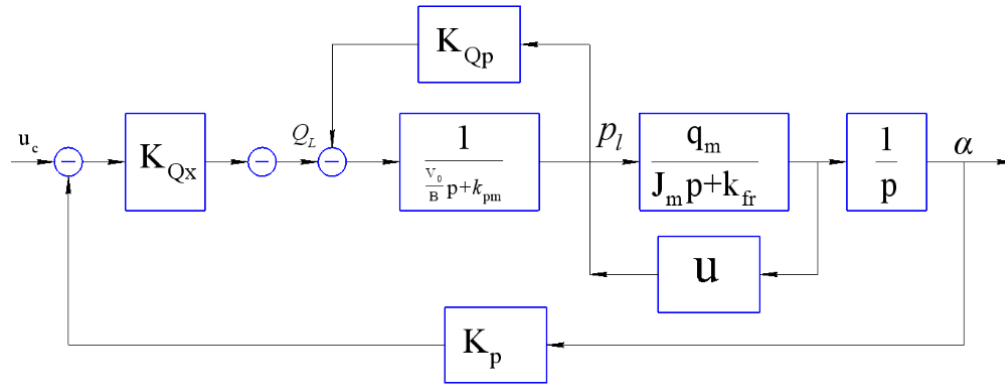

FIGURE 3. Block diagram of the optimal system

The following values of the parameters were used in the simulation:

$$K_{Qx} = 1,865 \text{ m}^2 / \text{c}; K_{Qp} = 1,259 \text{ m}^3 / \text{Pa} \cdot \text{s}; B = 8 \cdot 10^8 \text{ Pa}; V_0 = 0,175 \cdot 10^{-3} \text{ m}^3; k_{pm} = 4,82 \cdot 10^{-12} \text{ m}^3 (\text{Pa} \cdot \text{s});$$

$$q_m = 5,68 \cdot 10^{-6} \text{ m}^3; k_{fr} = 0,973 \text{ Nms}; p_s - p_d = 1 \cdot 10^7 \text{ Pa}; k_q = 8,34 \cdot 10^{-4}.$$

Figures 4 and 5 show the changes in system pressure and the angular displacement of the hydraulic motor shaft, both without and with the stabilizing function taken into account.

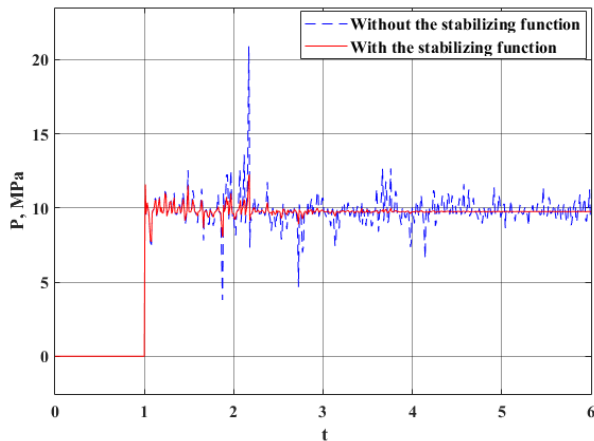

FIGURE 4. Change in hydraulic system pressure without and with the stabilizing function

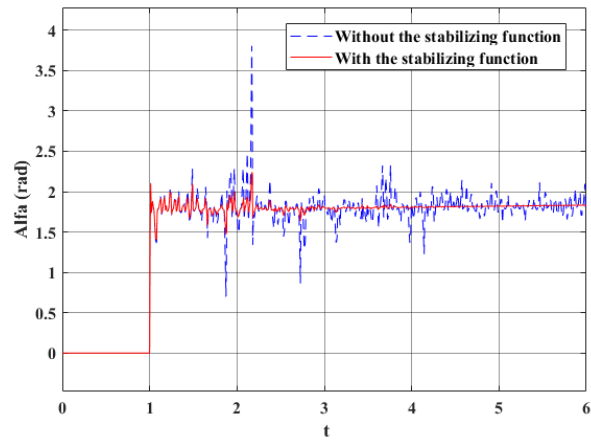

FIGURE 5. Change in the angular displacement of the hydraulic motor shaft without and with the stabilizing function

As can be seen from Figures 4 and 5, the proposed stabilizing function, which depends on the moment of inertia reduced to the hydraulic motor shaft of the controlled EHSS devices and the rotating parts of the hydraulic motor, as well as on the coefficient characterizing hydraulic friction in the hydraulic motor, ensures the stabilization of the system.

## CONCLUSION

A Simulink model for stabilizing the motion of an electro-hydraulic servo system has been developed. A Lyapunov function ensuring system stability was defined. To determine the optimal stabilizing function of the hydraulic system, the Bellman equation was obtained using the method of dynamic programming. Based on the proposed stabilization model of the EHSS, implemented in the Matlab-Simulink environment, variations in system pressure and the angular displacement of the hydraulic motor shaft were obtained, both with and without the stabilizing function, which adequately describes the operating process of the hydraulic system. An optimal stabilizing function for the electro-hydraulic servo system is proposed, which depends on the moment of inertia reduced to the shaft of the hydraulic motor from the controlled EHSS devices and rotating parts of the hydraulic motor, as well as on the coefficient

characterizing hydraulic friction in the motor. This function ensures system stabilization and can be applied when selecting compensating devices in the design of hydraulic systems.

## ACKNOWLEDGMENTS

This study was made possible by budget funding from the Uzbekistan Academy of Sciences. We express our sincere gratitude to the Academy for its ongoing support and commitment to advancing scientific research.

## REFERENCES

1. V.V. Solodovnikov et al. *Fundamentals of the Theory and Elements of Automatic Control Systems* (Mashinostroenie, Moscow, 1985), pp. 7–20. (in Russian)
2. N. Krasovski, “Problem of Stabilization of Controlled Motion,” In: I. G. Malkin, Ed., *The Theory of Motion Stability*, Nauka, Moscow, 1966, pp. 5-10. (in Russian)
3. I.G. Malkin, *Theory of the Stability of Motion* (Nauka, Moscow, 1966), pp. 8–13. (in Russian)
4. G.K. Annakulova and O.V. Lebedev, *Dynamic Modes and Chaotic Motions of Machine Drive Elements*, (Institute of Mechanics and Seismic Stability of Structures, Academy of Sciences of the Republic of Uzbekistan, Tashkent, 2010), pp. 4–16. (in Uzbekistan)
5. A.M. Lyapunov, *Selected Works. Papers on the Theory of Stability* (Nauka, Moscow, 2007), pp. 4–50. (in Russian)
6. G. K. Annakulova, B. J. Astanov and S. A. Saidov, “Stability of a Two-Stage Pneumo-Hydraulic Relay Controlled System with a Dead Zone,” in *ensuring seismic safety and seismic stability of buildings and structures, applied problems of mechanics*, AIP Conference Proceedings, edited by Abirov *et al.* (AIP Publishing LLC, Uzbekistan, 2025) **3265**, 070022.
7. V.M. Kuntsevich, *Synthesis of Automatic Control Systems Using Lyapunov Functions* (Nauka, Moscow, 2007), pp. 5–57. (in Russian)
8. E.S. Pyatnitsky, *Problems of Mechanical Engineering and Machine Reliability. Letters* **5**, 74–81 (1990). (in Russian)
9. E.S. Pyatnitsky, *Automation and Remote Control. Letters* **7**, pp. 19–37. (1993). (in Russian)
10. K.A. Pupkov and N.D. Egupov, *Methods of Classical and Modern Control Theory. Vol. 4: Theory of Optimization of Automatic Control Systems* (Bauman Moscow State Technical University Publishing House, Moscow, 2004), pp. 8–70 p. (in Russian)
11. R.E. Bellman, I. Glickberg and O.A. Gross, *Some Aspects of the Mathematical Theory of Control Processes*, (Santa Monica, California, 1958), pp. 150–155.
12. E. Lewis and H. Stern, *Hydraulic Control Systems* (Mir Publishers, Moscow, 1966), pp. 11–20. (in Russian)
13. N.S. Gamynin, *Fundamentals of the Servo Hydraulic Drive* (GNTI, Moscow, 1962), pp.4–18. (in Russian)
14. N.S. Gamynin, *Hydraulic Control Drive* (Mashinostroenie, Moscow, 1992), pp. 60–76. (in Russian)
15. V. Carlos, A. Stanislav, B. F. Leonid and M.F. Leonid, “Time Varying Gain Differentiator,” in *A Mobile Hydraulic System Case Study-2005*, edited by I. Kolmanovsky (IEEE Publishing, 2005), pp. 1-11.
16. S. Madanipour, *Indian J.Sci.Res. Letters* **1**, 770–774. (2014).
17. L. Chunying, et al., “Research of PID algorithm for valve controlled hydraulic motor variable rate fertilizer control system,” in *Computer and Computing Technologies in Agriculture VII: 7th IFIP WG 5.14 International Conference, CCTA 2013*, edited by D. Li, Y. Chen (Springer Publishing, 2014), pp. 315–326.